

SmartArm is a flat panel monitor mounting system, featuring quick and easy monitor removal, fine height adjustment and complete flexibility.

The system is designed to meet changing monitor specifications and configurations, in either landscape or portrait orientation. Extensions can be added with no disruption to existing monitors.

Whether you require a single monitor mount or a fully tiled double tier array, SmartArm delivers enhanced performance with fully integrated fitting options.

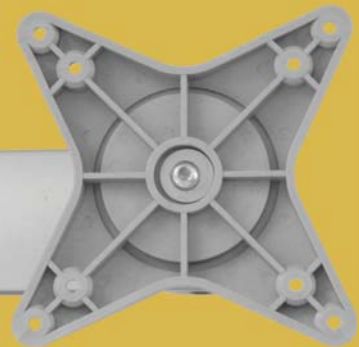

SmartArm



continuum™

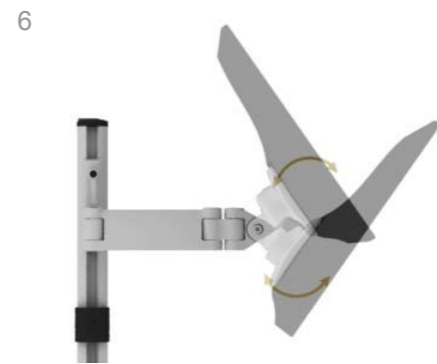
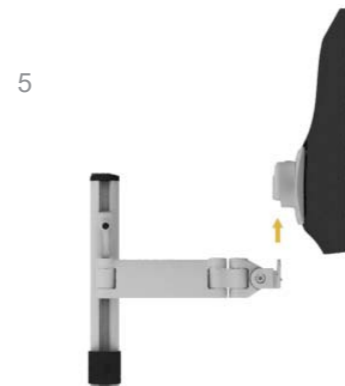
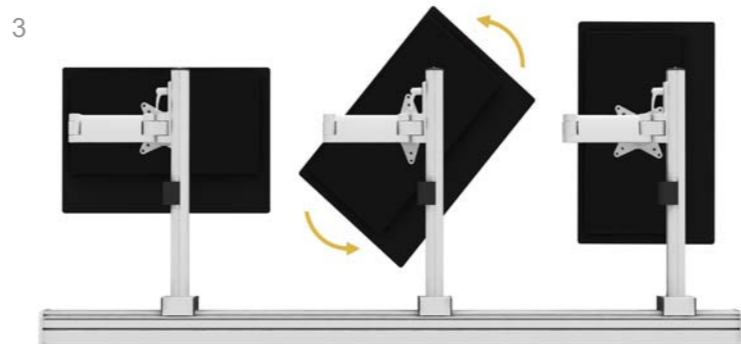
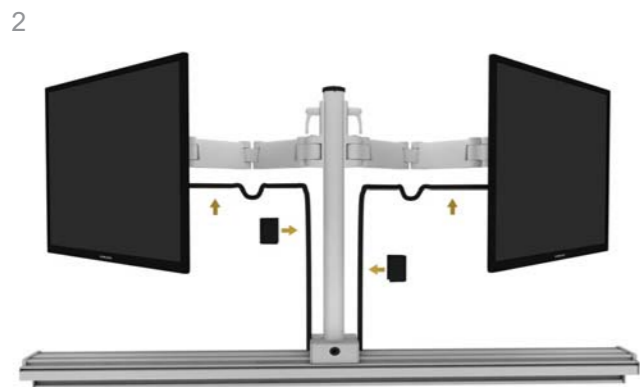
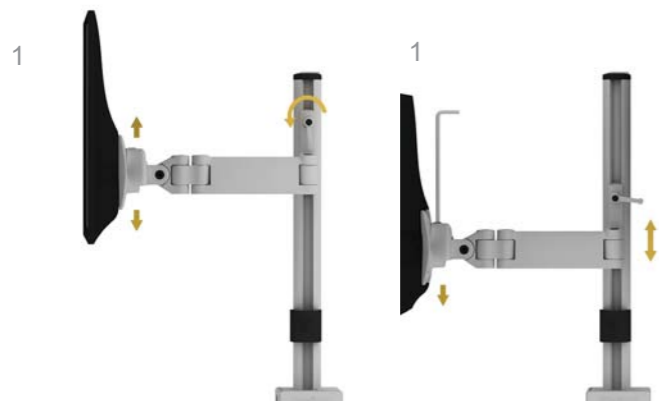

1 locking height slide bracket and fine height adjustment

2 semi concealed cable management

3 90° monitor rotation, landscape or portrait

4 maximum adjustability

5 two-handed quick release snapping vesa hub for safe screen removal

6 screen tilt

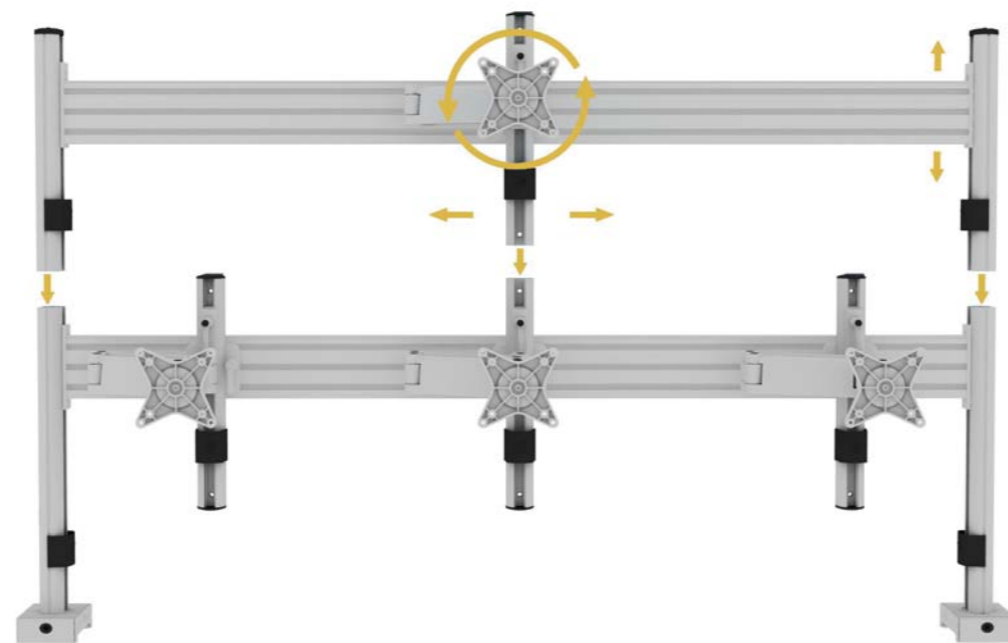
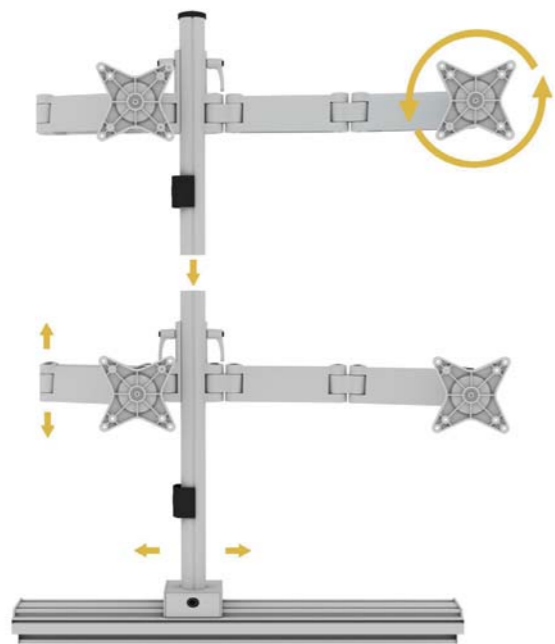

height alignment guide

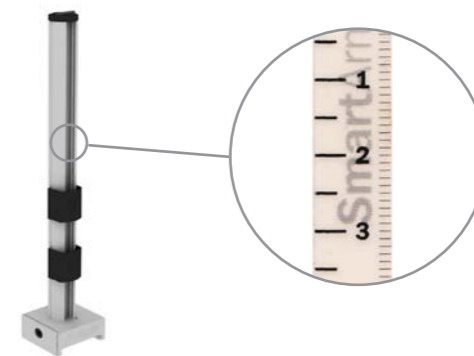

standard finish silver, also available in black or white



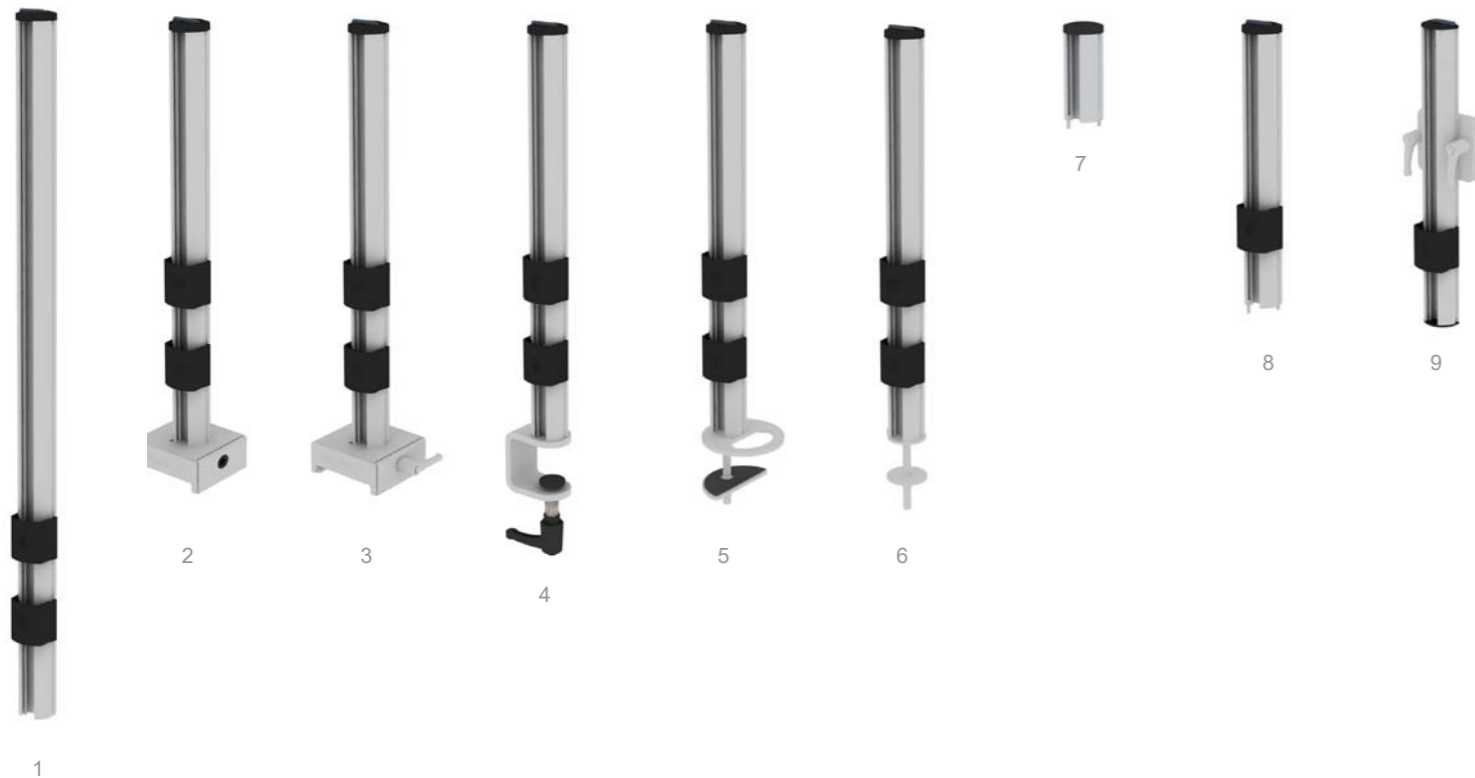

- 1 extended 815mm/32" pillar
- 2 pillar with monitor rail clamp (locking bolt)
- 3 pillar with monitor rail clamp (locking handle)
- 4 pillar with desk edge clamp 490mm/19.3"
- 5 pillar with cable grommet fixing 490mm/19.3"
- 6 pillar with through desk fixing 490mm/19.3"
- 7 extension pillar 100mm/3.9"
- 8 extension pillar 325mm/12.8"
- 9 half round panel mount with rail bracket and handles 330mm/13"
- 10 no link arm with slide bracket
- 11 one link arm with slide bracket
- 12 two link arm with slide bracket

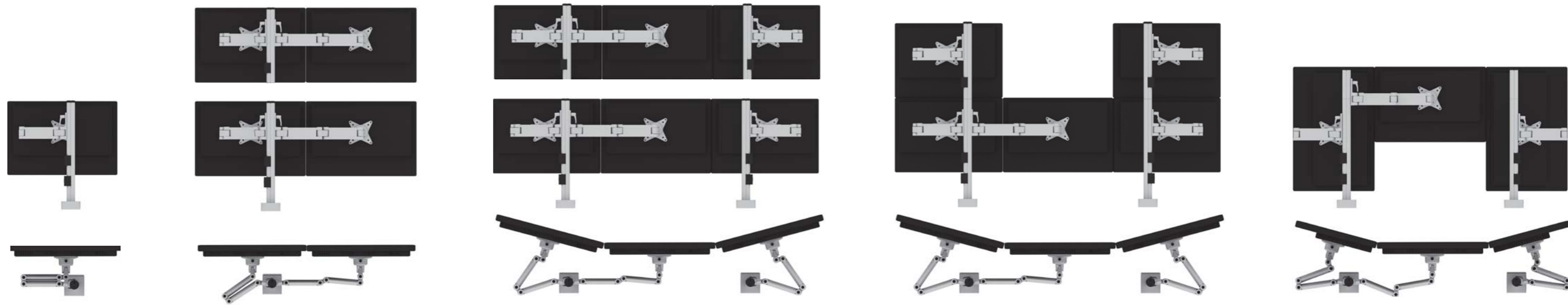



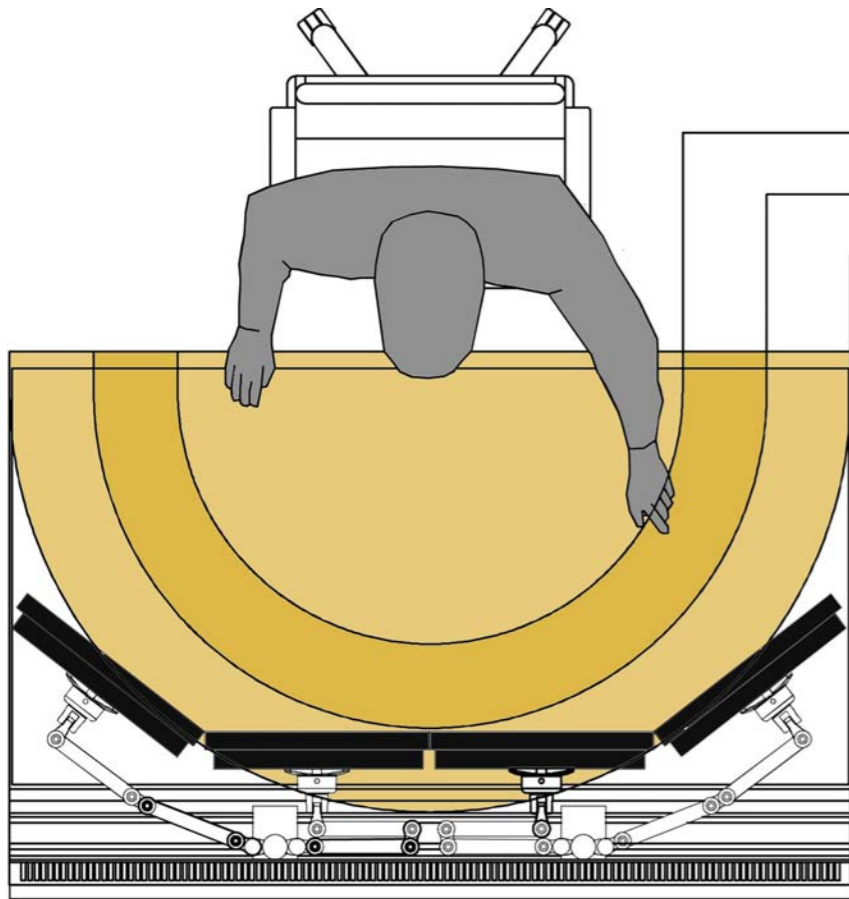

R17.7" / 450mm minimum viewing distance

R23.6" / 600mm optimum viewing distance

R29.5" / 750mm maximum viewing distance

ergonomics

SmartArm meets the highest ergonomic standards.

SmartArm has been independently tested by the Furniture Industry Research Association (FIRA), having received the FIRA ergonomic excellence award and is compliant to BS EN ISO 9241, 1999.

The system is designed to meet changing monitor specifications and configurations, in either landscape or portrait orientation. Extensions can be added with no disruption to existing monitors.

Whether you require a single monitor mount or a fully tiled double tier array, SmartArm delivers enhanced performance with fully integrated fitting options.

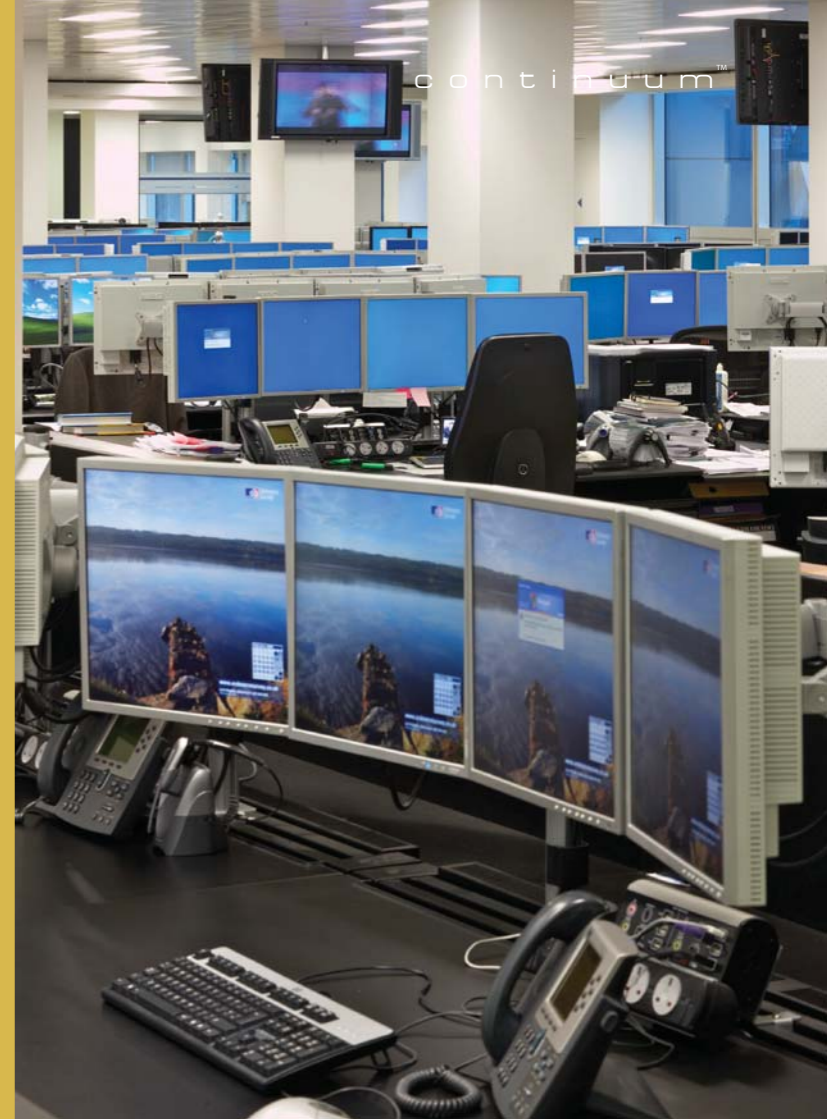

Our gas lift arm provides simple, instant adjustment for the user, ideal for desking scenarios where the ergonomic requirements differ from person to person.

Utilising a desktop mounted clamp and featuring integrated cable management, with optional USB connectivity. A double arm option is also available for dual screen configurations.

The `continuum` gas lift arm is the perfect fit for every office.

gas lift arm



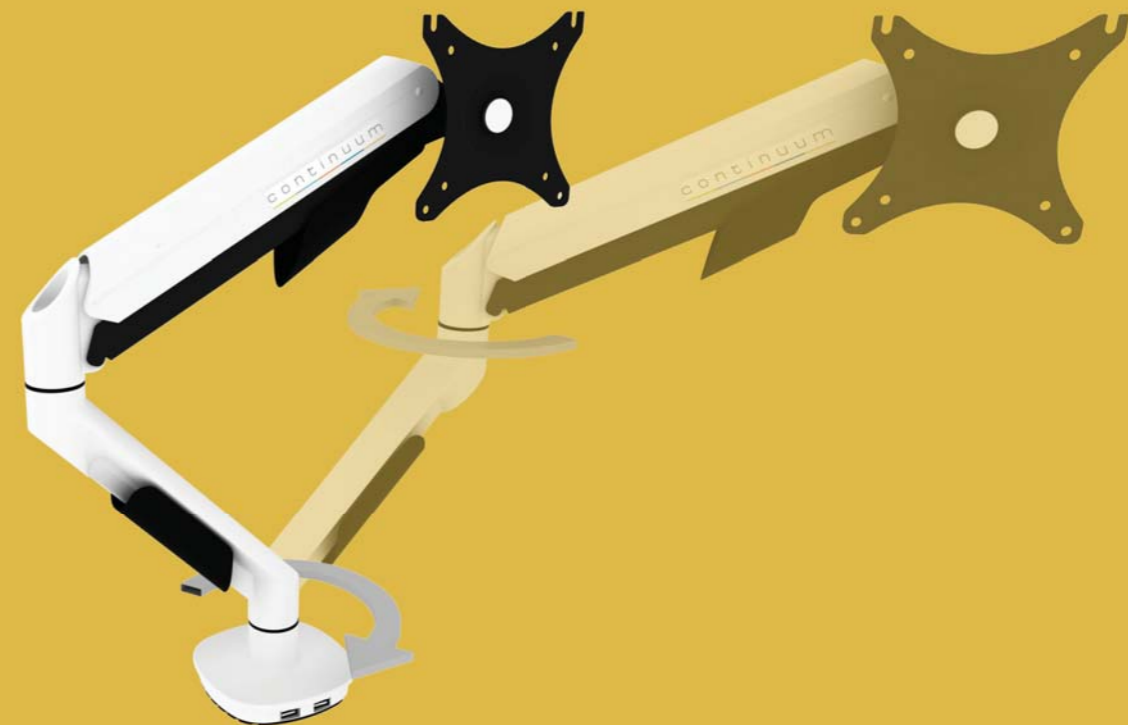

unlimited adjustability



USB data connections



integrated cable management



inclusive of desk edge clamp, through desk, and grommet fixing brace



white, silver, black colour options

minimum viewing distance

450mm / 17.7"

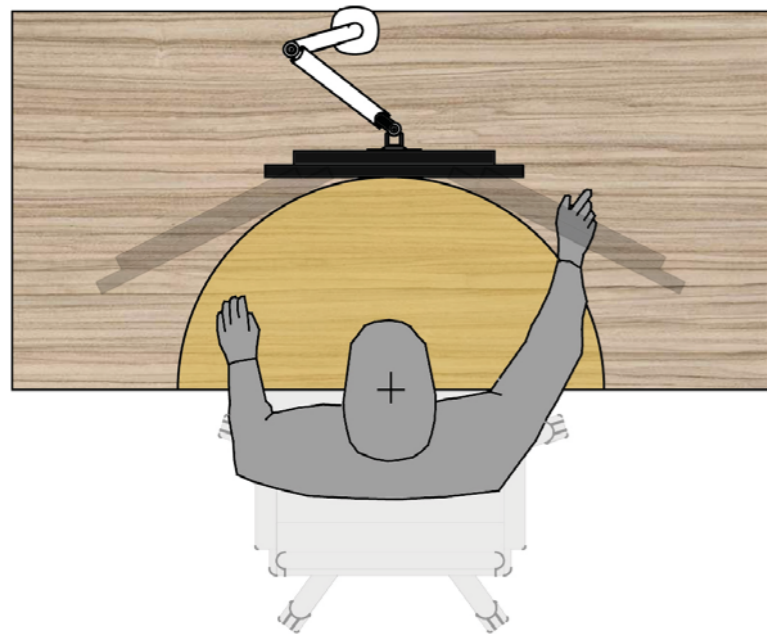

optimum viewing distance

600mm / 23.6"

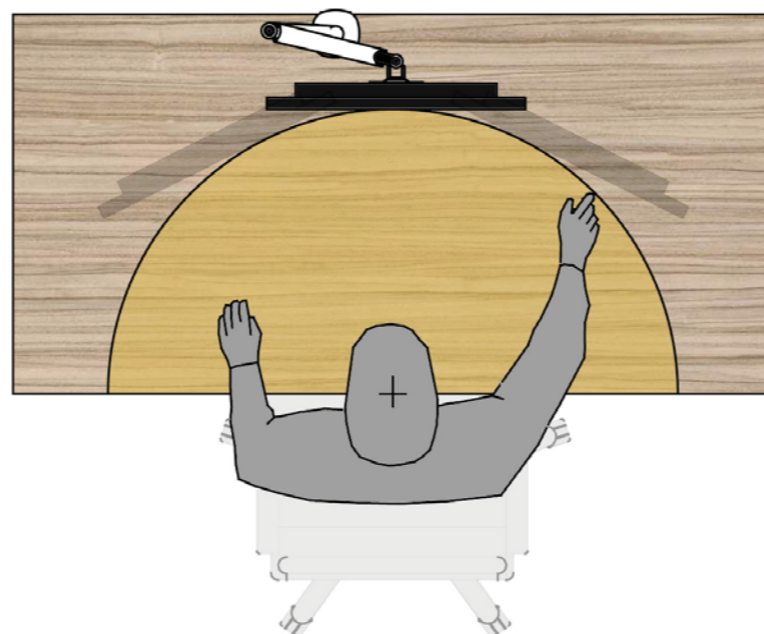

maximum viewing distance

680mm / 26.8"

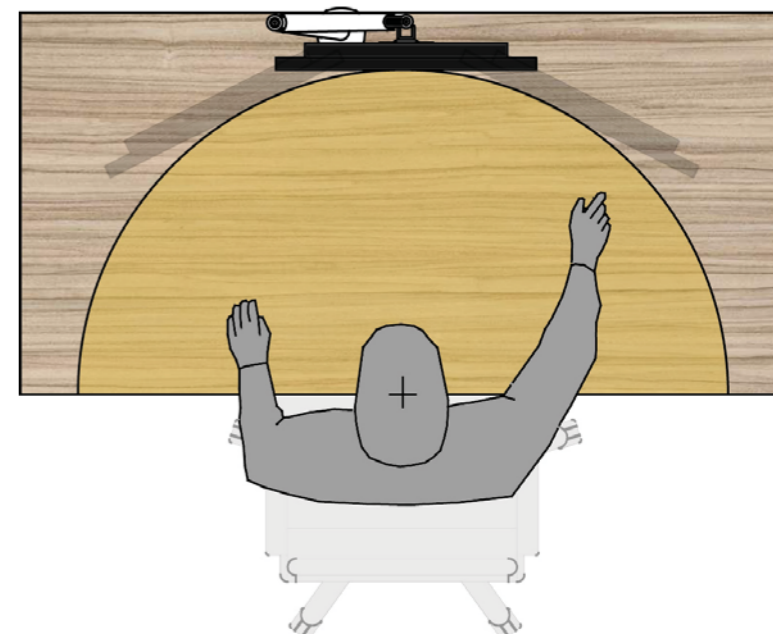

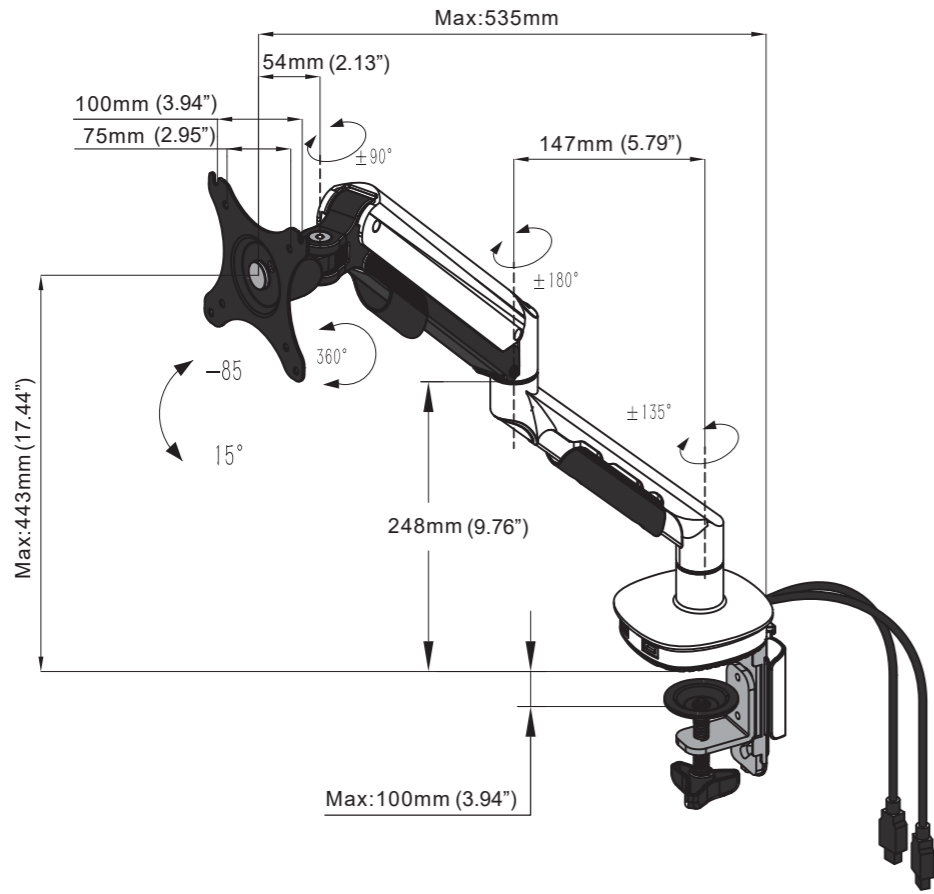

single arm

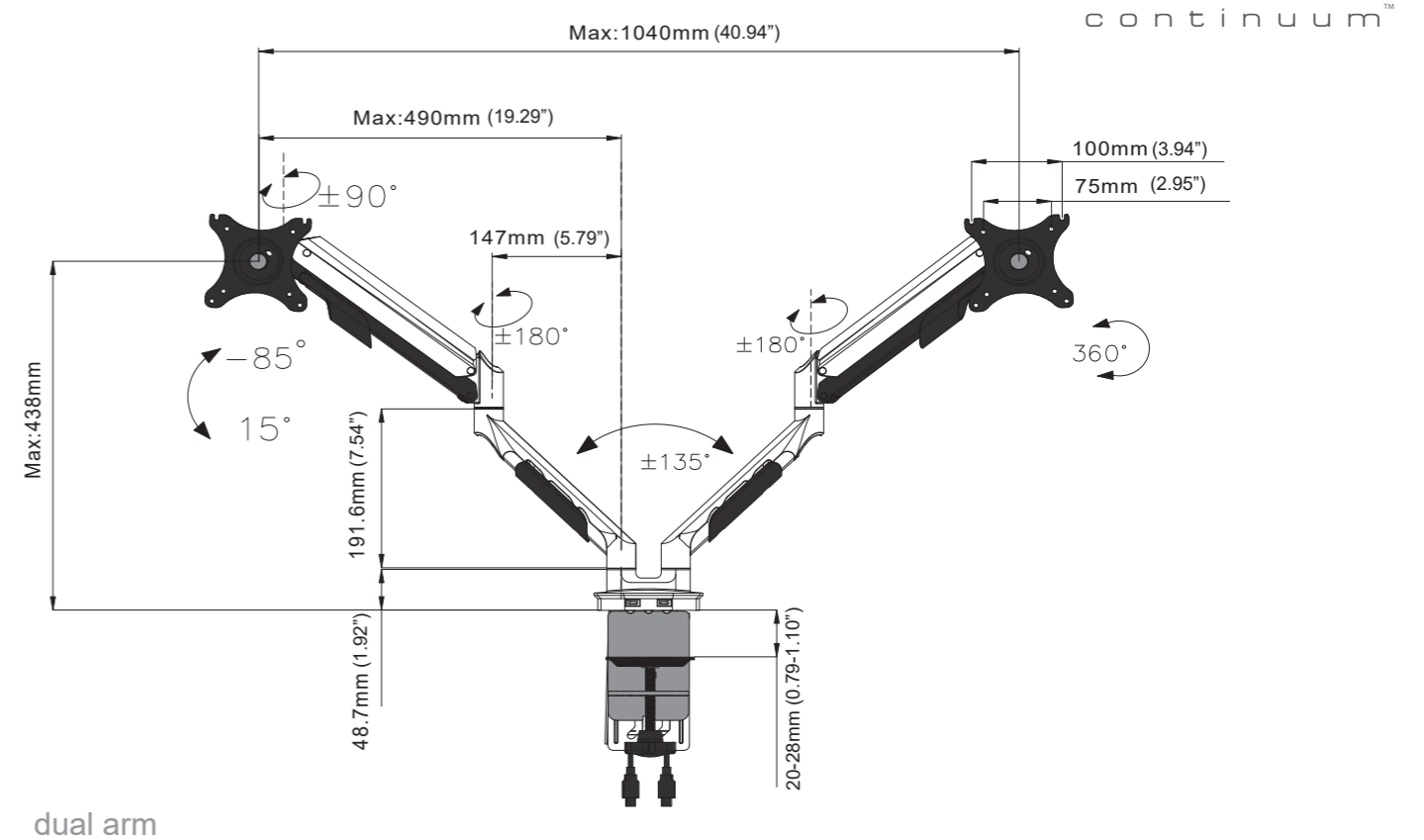

dual arm

continuum™

specification

We have been working with an international client base for over 25 years, producing differing product solutions to meet an array of differing specifications.

We have worked all over the world, managing and supporting projects at a local level with support from our international offices in the Americas, EMEA and APAC regions.

With three manufacturing hubs, our global distribution capabilities ensure we meet our timeline promises, having achieved a 100% success rate to date.

Class leading and innovative, **continuum™** will meet and surpass your expectations.

experience

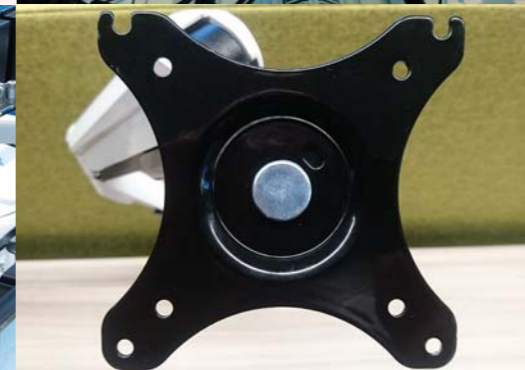

c o n t i n u u m

Technology desking™

Americas

39 Broadway
Suite 1640
New York
NY 10006

T: +1 212 257 6998

E: usinfo@technologydesking.com

Technology desking™

EMEA

Suite 2.01, Harbour Island
30 Harbour Exchange Square
London
E14 9GE

T: +44 (0)20 7837 3355

E: ukinfo@technologydesking.com

Technology desking™

APAC

15th Floor Hong Kong & Macau Building
156-157 Connaught Road
Central District
Hong Kong

T: +852 2868 3878

E: hkinfo@technologydesking.com

www.technologydesking.com